

(No Model.)

2 Sheets—Sheet 1.

A. JAMIESON.
DENTAL ENGINE.

No. 366,484.

Patented July 12, 1887.

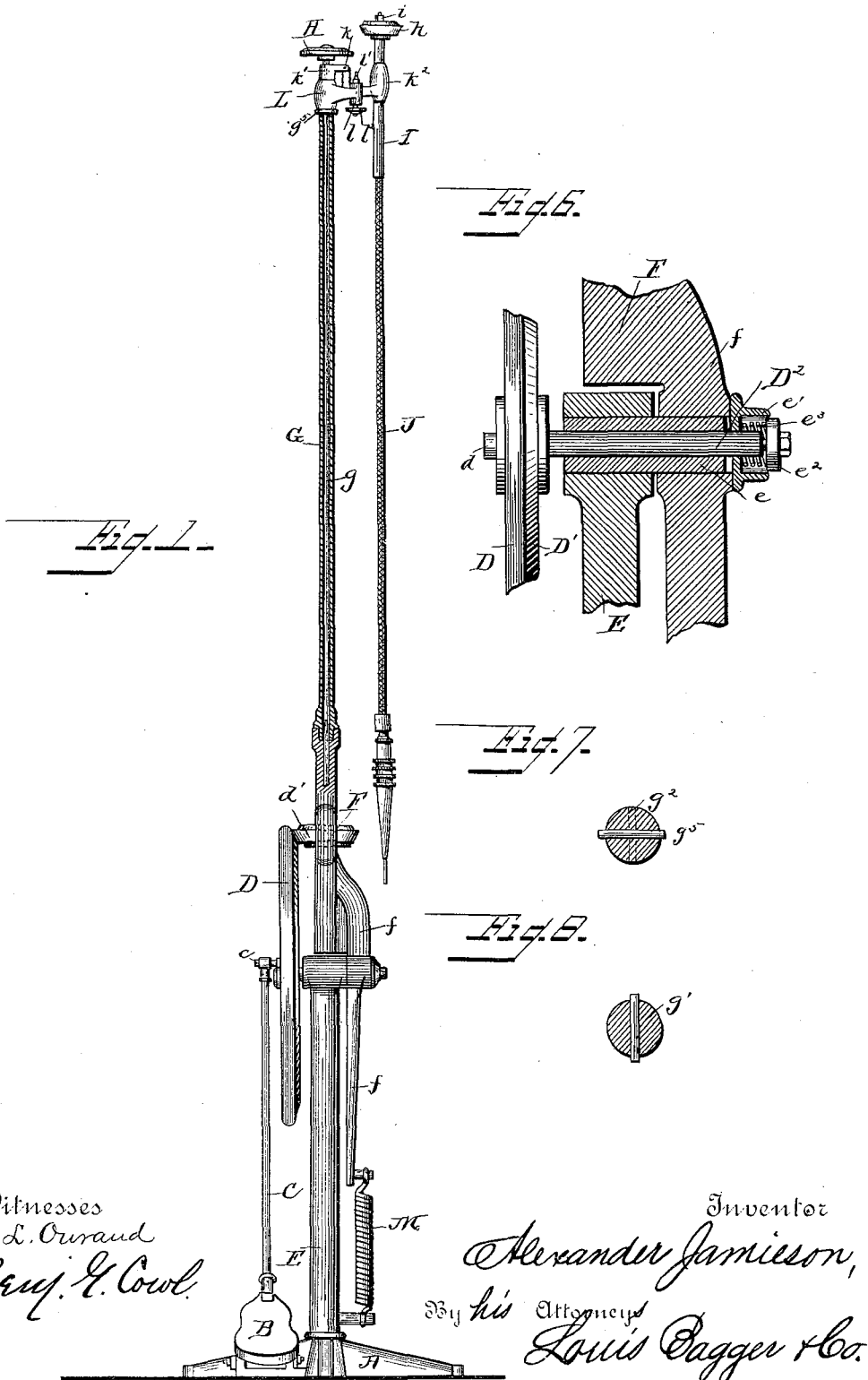

Witnesses
F. L. Orraud
Benj. G. Cowl.

Inventor
Alexander Jamieson,
By his Attorneys
Louis Cagger & Co.

(No Model.)

2 Sheets—Sheet 2.

A. JAMIESON.
DENTAL ENGINE.

No. 366,484.

Patented July 12, 1887.

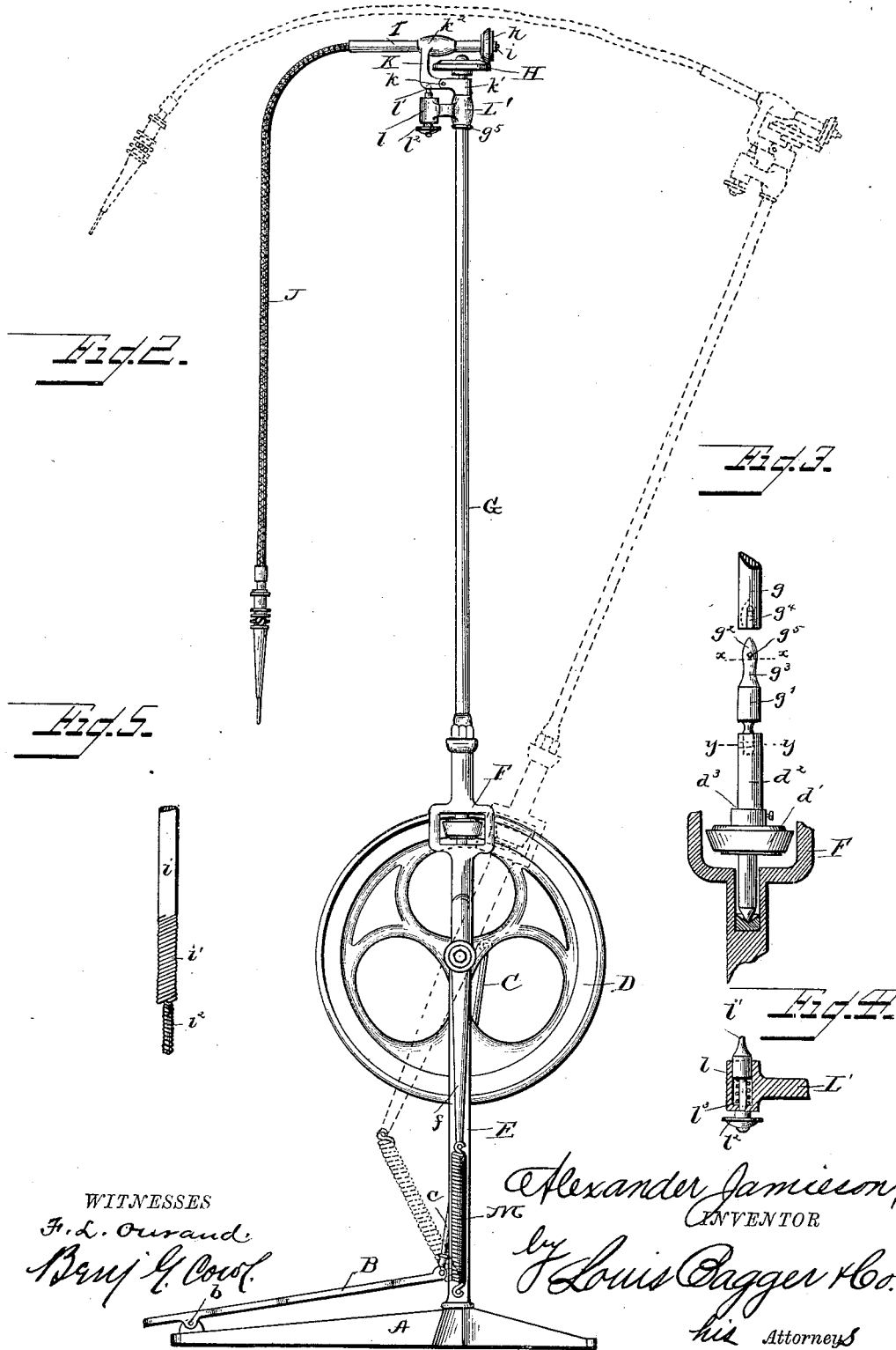

WITNESSES
F. L. Ouraud
Benj. G. Cook

Alexander Jamieson,
 INVENTOR
by J. Louis Cragger & Co.
 his Attorneys

UNITED STATES PATENT OFFICE.

ALEXANDER JAMIESON, OF LONDON, COUNTY OF MIDDLESEX, ENGLAND.

DENTAL ENGINE.

SPECIFICATION forming part of Letters Patent No. 366,484, dated July 12, 1887.

Application filed March 12, 1887. Serial No. 230,606. (No model.) Patented in England January 27, 1886, No. 1,253, and in Germany February 23, 1886, No. 36,726.

To all whom it may concern:

Be it known that I, ALEXANDER JAMIESON, a subject of the Queen of Great Britain, residing in the city of London, in the county of Middlesex and Kingdom of England, have invented certain new and useful Improvements in Dental Engines; and I do hereby declare that the following is a full, clear, and exact description of the invention, which will enable others skilled in the art to which it appertains to make and use the same, reference being had to the accompanying drawings, which form a part of this specification.

My invention has relation to that class of so-called "dental engines" which dispense with all driving cords and pulleys and are operated by frictional gearing; and it consists in the improvements in dental engines of that class, which will be hereinafter more fully described, and particularly pointed out in the claims.

In the accompanying drawings, Figure 1 represents a front elevation of my improved dental engine as it appears when out of gear and not in use. Fig. 2 is a side elevation showing the engine in gear and ready for use. Fig. 3 is a detail view, partly in section, illustrating the construction of the step-bearing, the frictional pinion which operates the vertical shaft, and showing, also, the construction of the compensation device. Fig. 4 is a sectional detail view of the spring device for releasing the horizontal arm to take it out of gear or put it into gear. Fig. 5 is a detail view illustrating the construction of the part rigid and part flexible horizontal arm. Fig. 6 is a sectional detail view through the bushing of the axis of the fly-wheel and its bearing; and Figs. 7 and 8 are cross-sections through $x x$ and $y y$ in Fig. 3, respectively.

Like letters of reference denote corresponding parts in all the figures.

My improved engine is mounted upon a base, A, of suitable shape and construction, upon which at b is the fulcrum for the treadle B, the inner end of which is connected by a pitman or connecting-rod, C, to the crank-pin c of the fly-wheel D, which imparts motion to the engine.

That side of the wheel D which faces the engine is turned off to form a bevel, D' , as illustrated more clearly in Fig. 6, which is

turned perfectly true and polished. The axis D^2 of the fly-wheel is inserted through a bushing or bearing, e , of suitable metal, which is inserted through and fixed in a box or bearing formed in the enlarged head or upper portion of the pillar E, the lower end of which is firmly fixed in the base A.

The bushing e projects on one side of the pillar E, so as to form a laterally-projecting support for the part F, which is adapted to oscillate upon said bearing and carries the upper working parts of the engine, as will be hereinafter described. This movable part F is constructed with a hollow box, e' , containing a coiled spring, e'' , through the coils or helices of which the outer end of shaft D^2 projects, as illustrated in Fig. 6, said shaft having an end or disk, e^2 , at its outer end, closing the opening to the box and bearing against the coiled spring, so that the tension of the latter will operate to draw shaft D^2 and its wheel D toward the fixed pillar E and movable part F. The part F is further provided with a tail-piece or downward extension, f , which is connected by a spring, M, with the lower part of the fixed pillar E, or with the base. This spring M is sufficiently strong to exercise a pull in a downward direction upon the tail-piece f sufficient to keep the upper part, F, in a vertical position under normal conditions, unless this part F, with its appurtenances, to be hereinafter described, is thrown out of the perpendicular, as indicated by the dotted lines in Fig. 2; but as soon as the upper part of the engine is released from lateral pressure the tension of spring M will cause it to immediately resume its normal perpendicular position. That portion of the part F which is opposite to the rim of the upper part of the fly-wheel is branched or bifurcated to make room for the frictional pulley d' . This and the other friction-pulleys used in my engine are, by preference, constructed each of a series of leather disks placed together, one upon another, and compressed between two metal disks, after which their peripheries are turned up true by a lathe. The friction-pulley d' is provided with a sleeve or collar, d^2 , through one side of which a set-screw is inserted adapted to bear with its inner end against the shaft d^2 , so that by tight-

ening said set-screw the pulley will be fixed upon the shaft. This construction permits of the adjustment of the pulley upon the shaft, so as to compensate for wear, owing to the frictional contact between the leather rim of the pulley and the polished and beveled rim of the wheel D.

The shaft d^2 , hereinbefore referred to, is stepped in a bearing in the part F, as shown more clearly in Fig. 3, and passes through a tubular extension of said part F, within which it is connected to the connecting-rod g , which works inside of the vertical hollow pillar G, the lower end of said hollow pillar being suitably attached to the upper end of the tubular part F. It is this connecting-rod g which imparts motion to the friction-pulley H, secured at its upper end, and through it to the pulley h and arm i , with its flexible connection J, the outer end of which is provided with a suitably-constructed tube-holder for holding the burrs or other tools which it is desired to use in the engine.

The connection or coupling between the friction-pulley d and rod g is not a rigid one, but consists of three separate pieces, which are coupled and connected in such a way that the connecting-rod is capable of yielding before a sudden twisting strain and then recovering itself without suffering permanent distortion or interfering with the normal practical continuity of the whole connection.

This part of my invention is carried out as follows: The upward continuation of the pinion-spindle d^2 is bored out to receive the lower end of an intermediate piece, g' , the upper end or nose, g^2 , of which is made of an elliptical section in elevation and connected to the body of the piece by a neck, g^3 . The lower end of the rod g is bored out to receive the nose of the intermediate piece. Two notches, g^4 , are formed diametrically across the end of the rod to receive two corresponding pins, g^5 , projecting, respectively, from opposite sides of the thick part of the nose g^2 . A second pair of notches is cut in the end of the spindle d^2 , and two corresponding pins projecting laterally from the lower extremity of the intermediate piece g' fit therein. The pins fit into the notches without play.

When the engine is running without strain, the intermediate piece is in the position illustrated in Fig. 3, the rod g being down over the nose g^2 and the notches g^4 embracing the pins g^5 ; but so soon as the rod g is subjected to any twisting strain it buckles in the usual way against the opposite sides of the pillar G, its bored-out end riding up the nose g^2 , while one of the semicircular faces of its extremity, according to the direction of the strain, enters the neck g^3 . As the rod g recovers itself, it elongates, and its end rides down the nose g^2 , the mechanical connection between the pinion d and the wheel H having been throughout maintained by the pins and notches.

A second advantage of this construction is the facility with which the wheel H and the

rod g , as well as the other parts, can be taken out for cleaning or repair.

The pinion h is fast on the end of the rigid part i of the compound core, the construction of which is illustrated in Fig. 5. The flexible part of this core is composed of two spirals, i' i'' , respectively right and left handed. The ends are incorporated with the rigid part i and the tool holder, respectively, in any suitable way.

The rigid or solid portion of the horizontal revolving arm, which is provided with the friction-pulley h at its outer end, has its bearing in and revolves in a tube, i , which is fixed in a collar, k^2 , at the upper end of a bracket, K, the arm of which is hinged at k in another arm extending laterally from a socket, k' , which fits upon the upper end of the hollow pillar G, so as to revolve freely thereon. The upper end of said pillar is provided with a fixed collar or shoulder, which forms a bearing or support for a sleeve, L, inserted upon the upper end of pillar G, and revolving freely thereon. Said sleeve L is provided with a lateral arm or extension, L' , the outer end of which forms a socket, l , inside of which works a spring-actuated pin, l' , having a milled head, l^2 , at its lower end. The tension of the coiled spring l^3 operates to force the projecting upper end of the pin in an upward direction, so that when sleeve L is placed in a position on the pillar G to register with the bracket K the upper end of said spring-actuated pin will be forced into a small recess in the lower end of said bracket, as shown in Fig. 2, so as to maintain the sleeve k^2 , with its tubular arm I, in a horizontal position, thereby bringing the friction-pulley h in frictional contact with the horizontal friction-pulley H. The tension of the coiled spring l^3 also operates to compensate for wear of the two pulleys H and h , so that these will always be in frictional contact with each other when the apparatus is adjusted in the position shown in Fig. 2. When the apparatus is not in use, the spring-actuated supporting-pin l' is released from the bracket K and swung to one side of the same, which permits said bracket, with the parts secured thereto, to drop into the vertical position illustrated in Fig. 1.

Although, for the sake of convenience, I prefer to use a spring-actuated pin in the socket l , yet it is obvious that by making said socket screw-threaded a screw may be used therein for the purpose of supporting the bracket K in its proper operative position, and compensating for wear of the friction-pulleys H and h .

Having thus described my invention, I claim and desire to secure by Letters Patent of the United States—

1. The combination of the fixed pillar E, bushing e , oscillating part F, having tail-piece f , adjustable friction-pulley d , beveled friction-wheel D, having a shaft projecting beyond the bushing and provided with disk e^3 at its outer end, spring e' , and the spring M, all

constructed and combined to operate substantially as and for the purpose set forth.

2. The combination of the shaft d^2 , adjustable friction-pulley d' , connecting-piece g' ,
5 constructed with the reduced part or neck g^3 , an enlargement, g^2 , connecting-rods g , and the pins inserted through and connecting said parts, substantially as and for the purpose set forth.

10 3. The combination of the pillar G, revolving sleeve L, pin l' , and hinged bracket K, substantially as and for the purpose set forth.

15 4. The combination of the hollow pillar G, central connecting-rod, g , having the friction-pulley H at its upper end, sleeves k' , provided

with a hinged bracket, K, supporting the tubular bearing I, revolving shaft i , provided at one end with a flexible connection and at its opposite end with a friction-pulley, h , revolving sleeve L, and spring-actuated pin l' ,
20 adapted to support the hinged bracket with its tubular bearing I in a horizontal position, substantially as and for the purpose set forth.

In testimony that I claim the foregoing as my own I have hereunto affixed my signature
25 in presence of two witnesses.

ALEXANDER JAMIESON.

Witnesses:

FREDERICK WESTFIELD,
WILLIAM ROBERTSON.